

APPLICAZIONI

Elettropompe sommerse multistadio per pozzi profondi da 4" (DN 100 mm). Particolarmente adatte per applicazioni civili e industriali, alimentazione getti d'acqua e fontane, impianti antincendio, l'irrigazione in generale e per l'approvvigionamento di acqua pulita.

APPLICATION

Multistage submersible water pumps for 4" deep wells (DN 100 mm). Particularly suitable for civil and industrial purposes, for sprinkler and food irrigation plants, in fire installations and generally speaking for clean water supplying.

LIMITI D'IMPIEGO

- Temperatura liquido fino a 35°C
- Contenuto di sabbia max. 60 g/m³
- Partenza /ora 20 max.

OPERATING CONDITIONS

- Liquid temperature up to 35°C
- Sand content max. 60 g/m³
- Start/hour 20 max.

MOTORE

- Motore elettrico ad induzione a 2 poli (n=2850 min⁻¹)
- Motore sommerso in bagno d'olio
- Isolamento Classe F
- Protezione IP 68
- Servizio continuo

MOTOR

- Two-pole induction motor (n=2850 min⁻¹)
- Submersible motor in oil bath
- Class F Insulation
- IP 68 Protection
- Continuous duty

MATERIALI MOTORE

- Camicia esterna Acciaio inox
- Albero motore Acciaio inox
- Fondello Tecno-polimero
- Supporto superiore Ottone

MOTOR MATERIALS

- External casing Stainless steel
- Motor shaft Stainless steel
- Bottom plate Tecno-polymer
- Support Brass

MATERIALI POMPE

- Camicia esterna Acciaio inox
- Albero motore Acciaio inox
- Stadi e giranti Acciaio inox

PUMP MATERIALS

- External casing Stainless steel
- Motor shaft Stainless steel
- Stages and impellers Stainless steel

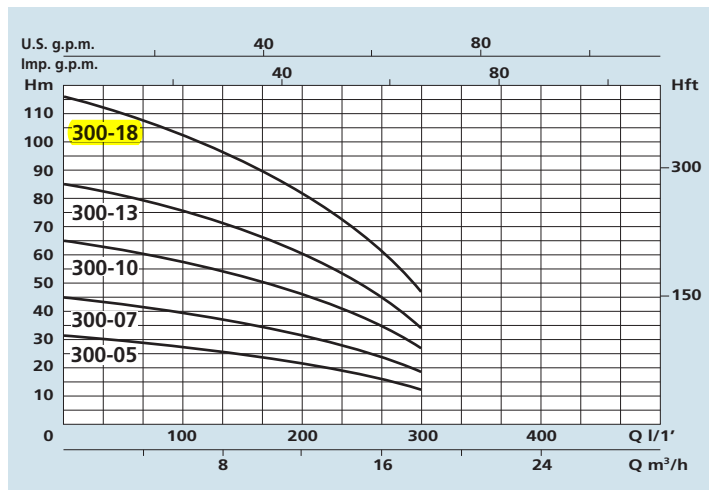

Tipo - Type	DIMENSIONI - DIMENSIONS mm		
	A	B	C
SXM-SXT 300-05	447	505	952
SXM-SXT 300-07	430	635	1065
SXT 300-10	447	830	1277
SXT 300-13	555	1025	1580
SXT 300-18	675	1350	2025

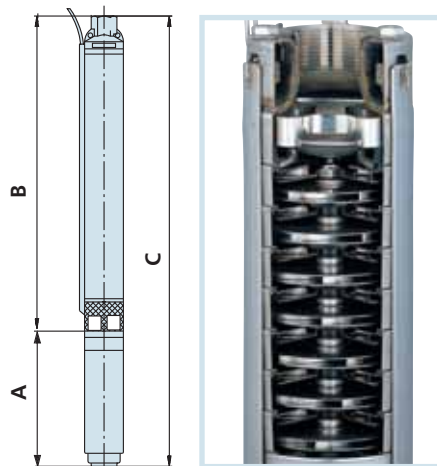

SX 300



DATI TECNICI - TECHNICAL DATA

TIPO - TYPE		POTENZA NOMINALE NOMINAL POWER P2		Stadi Stages	Q = PORTATA - CAPACITY											DNM		
Monofase Single-phase	Trifase Three-phase	HP	kW		m³/h	0	3,6	5,4	6	7,2	8,4	9,6	10,8	12	15		18	
230V-50Hz	230/400V-50Hz				lt/1'	0	60	90	100	120	140	160	180	200	250	300		
SXM 300-05	SXT 300-05	2	1,5	5	H (m)	32			29	28	27	26	25	23	19	13	2"	
SXM 300-07	SXT 300-07	3	2,2	7		45				40	39	37	36	35	32	26	18	2"
	SXT 300-10	4	3	10		65				58	56	54	52	50	46	38	26	2"
	SXT 300-13	5,5	4	13		85				75	72	70	67	65	60	49	34	2"
	SXT 300-18	7,5	5,5	18		117				104	100	97	93	90	83	68	46	2"